

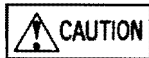

- Never adjust the knobs on the controller unit while driving as it is extremely dangerous.



- Never disassemble this product.
- If any unusual engine characteristics arise during use of this unit, discontinue use immediately and contact our office.
- Read this instruction manual carefully before installation and proceed setting after you obtain full information of this unit and manual.
- If this unit is stalled erroneously, the vehicle and its related equipment will be damaged.



- Manufacturer is not responsible to the vehicle and its related equipments damaged due to erroneous wirings. Also manufacturer is out of responsibility for any damage and/or accident if this unit is equiped and set with vehicle not specified on this manual.

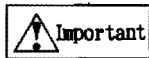

- Be sure to complete necessary points on Application Form of Inspection and Repair when the unit need an inspection and/or repair. Apply the inspection and/or repair to the dealers. It takes longer time for inspection and/or repair if the Application form is not attached.

SUPER AVC-R

SUPER ACTUATOR VALVE CONTROLLER TYPE-R

INSTRUCTION MANUAL

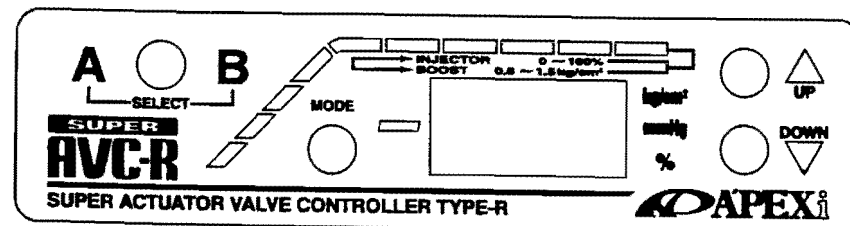

 **APEX**_i
APEX CO., Ltd. JAPAN

 **APEX**_i

Table of Contents

1. Introduction	1	9. Vehicle Specific Installation Table	
2. 1 Warnings	1	1. TOYOTA	13
3. Parts List	2	2. NISSAN	14
4. Part Names	2	3. MITSUBISHI	15
5. Product Main Features	3	4. MAZDA	15
6. Installation Procedures	3	5. SUBARU	15
[1] Fundamental Piping	3	10. Vehicle Specific Computer Location Diagram	16
1. Actuator Type	3	11. Vehicle Specific Computer Wiring Diagram	17
2. Waste Gate Type	4	1. TOYOTA	17
[2] Wiring , Unit Mounting	5	2. NISSAN	18
1. Electrical / Signal Harness Connection	5	3. MITSUBISHI	18
2. Coupler Harness Connection	6	4. MAZDA	19
3. Main Connection Diagram	6	5. SUBARU	19
7. Product Functions	7		
1. Control Unit	7	* Actuator Type Vehicle Specific Piping Diagram	20
2. Boost Pressure Regulating Solenoid Valve	7	1. Vehicles With Boost Pressure Regulating Solenoid Valve - 1	20
3. Pressure Sensor	7	2. Vehicles With Boost Pressure Regulating Solenoid Valve - 2	21
		3. JZA 80, JZS 147 Specific Piping Diagram	22
8. Operational Instructions	7	4. FD3S Specific Piping Diagram	23
[1] Set Up Mode	7	5. BD5, BG5 Specific Piping Diagram	24
1. Engine Type Setting	8		
2. Preset Boost Pressure Setting	8		
3. Preset Boost Duty Setting	9		
3-1. Actuator Type	9		
3-2. Wastegate Type	10		
4. Set Up Lock Function	11		
[2] Monitor Mode	12		
1. Boost Pressure Display Function	12		
2. Injector Pulse Display Function	12		

Super Actuator Valve Controller Type - R

1. Introduction

Thank you for purchasing the APEXi Super AVC-R. This is a highly efficient boost controller excelling in rapid boost response and stability. This unit can be installed on virtually any turbo vehicle ranging from normal engines to hard tuned engines with its self-learning function. Furthermore, the standard real time boost pressure display and real time injector pulse display have been included in this unit. Please be sure to read this manual completely and use the unit properly.

2. !WARNINGS ~ Please be sure to read~

* Although this unit may be installed on virtually any turbo vehicle ranging from normal, modified engines, to turbo upgrades, the unit utilizes the injector signal for its self learning function which limits its usage to Electronically Controlled Fuel Injection System Vehicles Running On Gasoline. Please be aware that the Self-Learning mode cannot have an accurate reading if the injector pulse display does not work and if the installation vehicle has an electrical current controller for the injector signal. (For instance: PZ 31, R 31)

* This unit may be programmed up to a maximum boost pressure of 2.0 (kg/cm2.) Raising the boost pressure above normal settings which exceeds the vehicle's fuel supply margin may lead to engine failure. When raising boost pressure, please raise the boost according to the margins of the injector, air flow meter, and fuel pump of the engine and turbo.

* Please be warned that our company is not responsible for ANY damages incurred to the engine, turbo and all related components due to unnecessary and excessive boost pressure levels.

* Some vehicles may have a fuel cut system when the boost pressure has been raised. Please release the fuel cut system in these cases. Please contact our company if there are any problems releasing the fuel cut system.

* Please use extra caution when proceeding with wiring or piping procedures. Our company is not responsible for any vehicle trouble resulting from faulty installation.

3. Parts List

1. Control Unit 1	2. Solenoid Valve ... 1	3. Pressure Sensor ... 1	4. Vehicle Interior ... 1 Wiring Harness
5. Vehicle Engine ... 1 Bay Harness	6. 6 pi hose 2m	7. 4 pi hose ... 50 cm	8. 6 pi hose clamp ... 12
9. 6 pi 3- way 2	10. 4 pi 3-way 1	11. Valve, Sensor ... 4 Mounting Bolt	12. Splitting Caps ... 4
13. Zip Ties ... 3 each (Lg, Sm)	14. Double - Sided ... 1 Tape	15. Mounting Rubber Plate	16. 8 pi-6 pi-8pi ... 1 3 way
17. 8 pi Hose Clamp 2	18. Nipple for ... 1 Wastegate	19. Orifice for ... 1 Wastegate	20. 8 pi 2 way ... 1
21. 4 pi ~ 6 pi ... 2 Replacement Adapter	22. Instruction ... 1 Manual		

4. Part Names

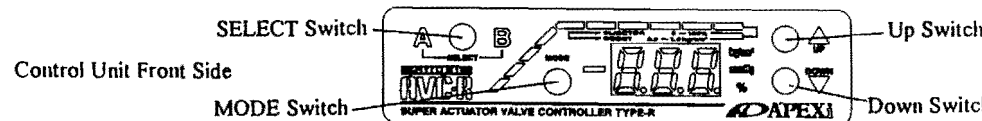

Control Unit Back Side

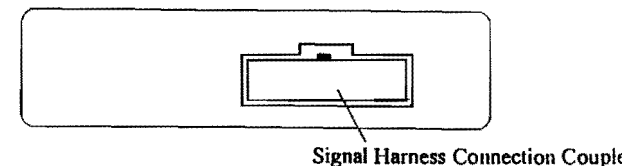

Specifications

Size 90 (W) x 25 (H) x 100 (D) mm
 Weight 125 g
 Display 7 Segment, 10 Chip Bar LED

Operational Electrical Current 10 ~ 16 V
 Operational Temperature -20~+60 °C

5. Product Main Features

- * Boost response is extremely fast.
- * Excels in stabilizing boost levels. (Especially in higher RPM's)
- * 2 Mode boost preset function
- * Self-learning function maximizes use of a highly efficient CPU
- * Achieves a level of perfect management of RPM specific boost management by combining the injector signal with the RPM signal.
- * Applies the best suited boost control even under high RPM levels.
- * Utilizes a wide-range absolute pressure sensor which accommodates high boost settings and changes in the air pressure.
- * Includes a high precision real time boost display and injector pulse display along with a digital and bar graph display. (Includes a maximum injector pulse indicator)
- * For extra safety, a preset boost locking feature is included. (set-up)
- * Easy to mount 1/4 DIN case size.

6. Installation Procedures

! Caution

- * Please be sure that the engine has fully cooled down before attempting any piping installation.
- * Please be sure to disconnect the negative terminal of the battery before attempting any wiring installation.
- * Please mount this unit away from direct sunlight.
- * Please mount this unit where the driver cannot reach. (Approximately 50 cm away from the driver's seat)

[1] Fundamental Piping

1. Actuator Type

1. Disconnect the hose from the turbine compressor to the actuator.
 2. Cut the necessary length of 6 pi hose and connect the compressor side to the NO side of the solenoid valve and the actuator side to the COM side of the valve as shown in the diagram.. (Leave the NC side of the valve open.)
 3. Mount the solenoid valve away from high temperature areas with the included bolts and Rubber Mounting Plate.
- ! Caution** Installing the solenoid valve near high temperature areas or mounting the valve without the rubber mounting plate may shorten the life span of the valve and in the worst cases break the valve.
4. Locate the hose from the surge tank to the fuel pressure regulator and insert the 4 pi 3 way into the 4 pi hose. Connect another 4 pi hose to the open side, cut an appropriate length and connect it to the pressure sensor.
 5. Mount the pressure sensor away from high temperature areas and use the included bolts to mount the sensor with the connected hose facing downwards.

! Caution Installing the pressure sensor near high temperature areas may affect the accuracy of the sensor and in the worst cases break the sensor.

6. Secure all hose connections with either a hose clamp or a zip tie and make sure that none of the hoses are crimped.

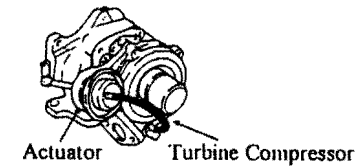

Actuator Type Piping Diagram

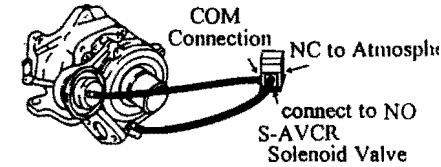

Boost Controller Kit Piping Diagram

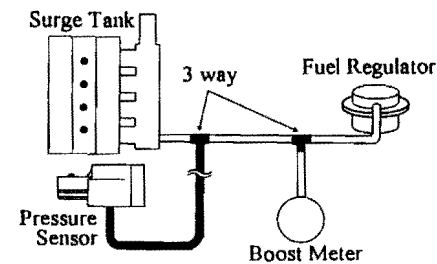

Pressure Sensor Piping Diagram

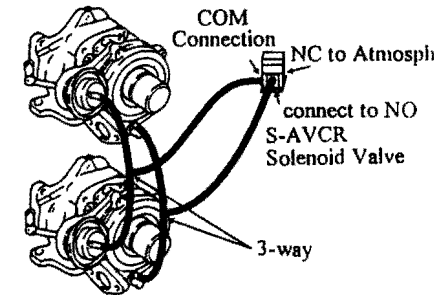

Twin Turbo Piping Diagram

* Vehicles with boost pressure regulating solenoid valves and other vehicles which require special piping examples have been listed in the back of this manual

2. Wastegate Type (Poppet Type)

1. Connect the included 6 pi wastegate nipple to the top nipple of the wastegate. (Please apply some sealing agent onto the threaded part of the nipple.)
2. Disconnect the nipple connected to the NO of the solenoid valve and connect it to the NC side of the solenoid valve. (Please apply some sealing agent onto the threaded part of the nipple.)
3. Attach the included orifice to the open NO side of the solenoid valve.
4. Connect the included 8 pi - 6 pi - 8 pi 3 -way in between the hose coming from the surge tank to the lower side of the wastegate. Cut and connect a 6 pi hose to the open side of the 3 way and connect it to the NC side of the solenoid valve. (The NO side of the valve is open to the atmosphere.)
- Connect a 6 pi hose to the nipple from step 1 and hose it to the COM side of the solenoid valve.
5. Please refer to steps 3 ~ 6 from the actuator type instructions.

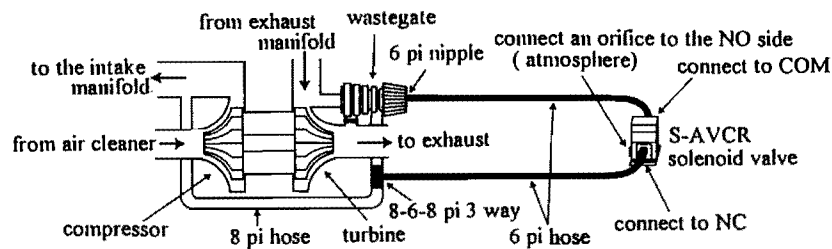

Wastegate type S-AVCR Piping Diagram

! Caution (Same for Actuator / Wastegate type)

* Some vehicles may come equipped with a boost pressure regulating solenoid valve. Please disconnect the hose from this unit and cap the unit off when installing the S-AVCR. (Failure to disconnect this solenoid valve may cause extreme boost increase.)

* Crimps in the hoses may cause the boost not to rise or in some cases the boost to rise too much.)

* Some boost meters may include an orifice in their 3 -ways. This unit will not operate correctly with those 3 ways. Please keep all other piping separate from this unit.

[2] Wiring, Unit Mounting

1. Electrical/ Signal Harness Connection

1. Please disconnect the negative terminal of the battery. Please note all radio and clock settings on a sheet of paper as they may be erased when the terminal is disconnected.

2. Please locate the vehicle engine control unit. (Please refer to the Vehicle Specific Computer Location Diagram)

3. While referring to the Vehicle Specific Computer Wiring Diagram, use the included Harness Splitting Caps to connect the 4 lead wires off of the Vehicle Interior Wiring Harness to the appropriate wires on the vehicle computer.

I. Connect the orange lead wire to the constant power wire.

II. Connect the red lead wire to the IG power wire.

III. Connect the black wire to the ground wire.

IV. Connect the blue wire to the injector signal wire.

(Please be sure to connect these wires to the vehicle side of the harness when using sub-computers such as the F' MANAGE.)

! Caution The self learning mode of this boost controller will not operate and proper boost control cannot be achieved unless the injector signal wire is connected. Please be sure to connect the injector signal wire.

4. Please be sure to cover all connections using the splitting caps with electrical tape.

2. Coupler Harness Connection

1. Connect the 8 pin coupler (white) of the Vehicle Interior Wiring Harness to the control unit.

2. Locate a hole suitable to run the 6 pin coupler of the Vehicle Engine Bay Wiring Harness into the vehicle interior. If no suitable hole is found, please drill a suitable hole. (Be sure not to damage any other existing wires, or hoses when opening the hole.)

3. Connect the 2 pin coupler of the Vehicle Engine Bay Wiring Harness to the 2 pin coupler of the Solenoid Valve and connect the other 3 pin coupler of the Vehicle Engine Bay Wiring Harness to the 3 pin coupler of Pressure Sensor.

4. Connect the 6 pin coupler from step #2 and connect it to the 6 pin coupler of the Vehicle Interior Wiring Harness.

5. Please secure all wiring with zip ties once the mounting location for the control unit and solenoid valve have been found.

6. Use the double - sided tape to mount the control unit and be sure to wipe off any excess oil from the mounting surface.

!Caution be sure to mount the unit in a position which does not interfere with driving operation. Avoid mounting the unit under direct sunlight, and heating ducts.

7. After checking for proper wiring and piping connections, reconnect the negative terminal of the battery to complete the installation process.

3. Main Connection Diagram

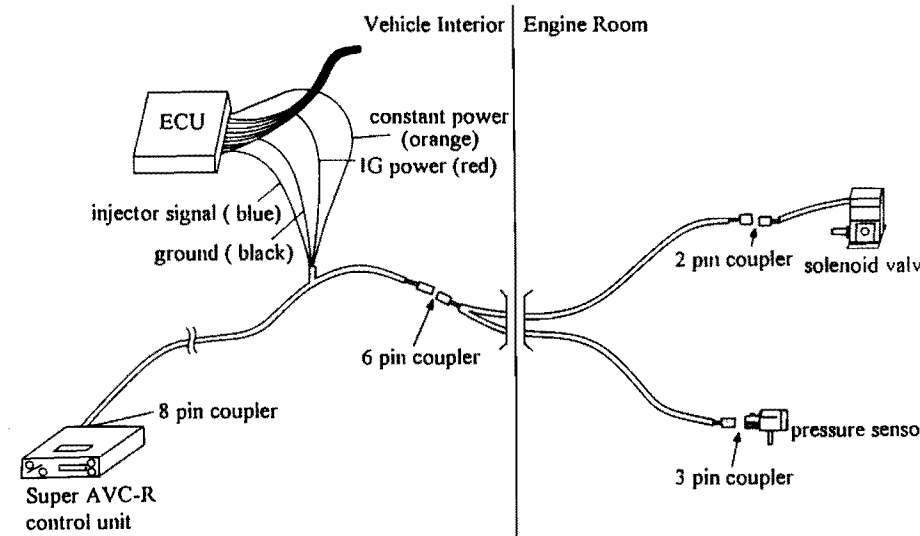

7. Product Function

1. Control Unit

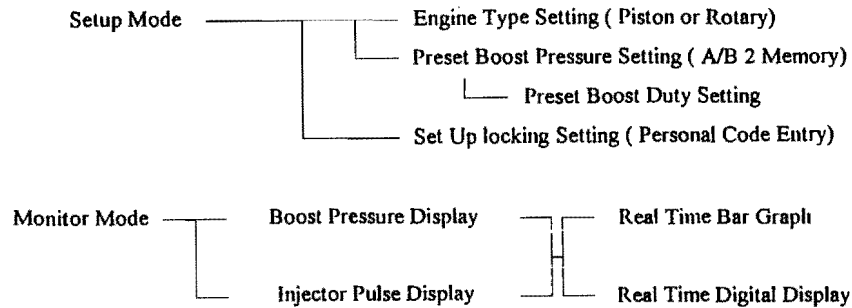

2. Boost Pressure Regulating Solenoid

This component receives its signal from the control unit and operates the valve either ON/OFF for a specified amount of time. By managing and changing this ON/OFF cycle (duty) in real time and monitoring the feedback information, the unit is able to commence proper boost control. The boost levels will proportionally become higher as the ON duration continues.

3. Pressure Sensor

The unit monitors the intake manifold pressure and uses this feedback to manage the boost pressure and real time boost display.

Because this sensor is an absolute pressure sensor, the sensor corrects its boost pressure according to the existing outside atmosphere pressure. The needle of some boost meters may not read the specified boost levels at all times because the meters read off of relative boost pressure while this pressure sensor works off of absolute pressure.

The needle of some boost meters may read higher than usual in areas of low atmospheric pressure and read lower in areas of higher atmospheric pressure.

8. Operational Instructions

[1] Set Up Mode

! Caution

* Be sure that the unit is properly set for the specified vehicle when installing for the first time, when any of the connectors have been disconnected, or when the battery terminal has been disconnected.

* Failure to properly set the unit for the specified application may lead to improper unit operation and may lead to serious engine damage. In the event that the vehicle sustains any damage, our company will assume no responsibility.

1. Engine Type Setting

Although this unit has a RPM separate self learning function, it is necessary to set the engine type (injector pulse type) because the unit uses the injector signal to read the engine RPM for the self learning function.

1. Turn on the Ignition ON key.
2. When using for the first time, all indicators will flash.

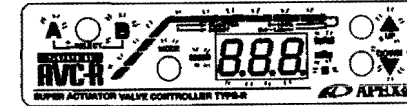

First Time Display

3. Press the SELECT switch.

4. Once the display has switched from the initial flashing, the display will show the preset boost setting (Initial preset A) and then the present boost pressure.

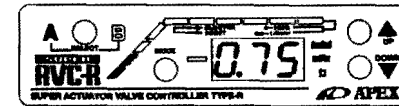

Displays initial boost setting of preset A

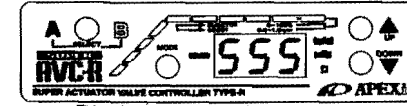

Displays present boost pressure

5. Press SELECT down along with the DOWN switch at this time.
6. The E-1 which appears on the screen denotes engine type setting.

E-1 stands for all piston motors. (Vehicles injecting fuel once every 2 engine cycles)

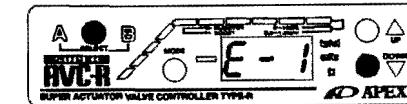

Displays initial boost setting of preset A

7. Press UP or DOWN for Rotary Engines.
8. The E-2 will appear in the display denoting rotary engines. (Vehicles injecting fuel once every engine cycle.)
9. Press MODE once the engine type has been set.
10. This completes the engine type setting.

IMPORTANT * Some piston engines use a simultaneous injection system for their fuel injection type. (ex: S13 etc.) Please use the rotary vehicle engine type setting for these vehicles.

2. Preset Boost Pressure Setting

This unit includes two settings in its memory for two different boost levels with the self learning function working for each setting. Because this unit completes its self learning mode under normal driving conditions, it requires only some simple steps unlike other systems which require a certain type of driving pattern.

1. Press the SELECT switch and then press A or B. (Initial setting is at preset A)
2. Once the selection has been made, press the UP or DOWN button to set the boost pressure. The initial settings are 0.75 kg/cm² for preset A and 1.00 kg/cm² for preset B. (Both presets A and B may be preset from 0.50 kg/cm² ~ 2.00 kg/cm² in 0.05 kg/cm² increments.)

! CAUTION The boost pressure may not be set under the factory boost setting (The operational actuator pressure. Raising the boost level to excessive levels may lead to engine damage. our company is not responsible for any damages due to excessive boost levels.)

3. Letting go of the button at the specified boost level will return the screen to the monitor mode completing the setting.



EX: 1.25 kg/cm2 for preset A

Displays present boost pressure

IMPORTANT* Pressing the UP/DOWN switch in succession after pressing the SELECT switch allows those commands to remain effective. Thus pressing the button only once will return the unit back to monitor mode.

3. Preset Boost Duty Setting

Although this unit uses feedback management and the self learning function to automatically control the boost pressure to the specified setting, the valve driving power duty must stay within a certain limit. Since this limit varies from vehicle to vehicle depending on engine tuning, it is necessary to set each and every individual vehicle.

3-1 Actuator Type

1. Press the SELECT switch for longer than 3 seconds.
2. Be sure to check that all of the LED'S other than the SUPER AVC-R logo and the digital bar graph have been turned OFF

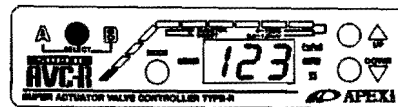

displays power OFF

3. Once the LED'S are turned off, this shows that the boost control management is OFF making the boost pressure only rise to the factory setting controlled by the factory actuator operation.
4. Drive the vehicle with the power OFF. At this point, attempt to drive in the gear with the highest load and check the peak boost level.
5. Normal actuators may range from 0.4~0.8 kg/cm2. The higher the boost level, the lower the duty cycle that is needed to reach the same boost level. As for the actual duty setting, the fundamental rule is if the boost setting is set for 1.00 kg/cm2 and the actuator pressure is 0.4 kg/cm2 the limit is 70% while a 0.8kg/cm2 actuator pressure would denote a 40% limit. Of course if the boost pressure is higher than this the duty limits would be lower and if the boost pressure lower, the duty limit higher.
6. Using the actual driving data as a base, set the duty setting corresponding to the actual boost pressure.
7. Press the SELECT switch once again for longer than 3 seconds and turn the power back ON.
8. Select one of the boost settings A or B.
9. Press the MODE button for longer than 3 seconds.
10. If the set boost level is A, then the initial setting will flash 30%. (B will flash 50%)

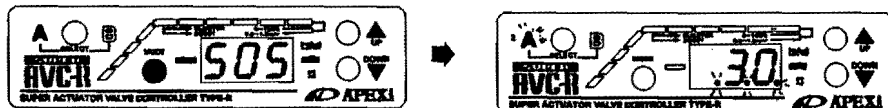

Displays the present boost level

Displays the duty level for preset A

11. Press the UP/DOWN switch to adjust the duty setting to the necessary levels. (The duty level settings for A/B range from 20%~90% in 2% increments.)

12. Press the MODE switch again to set the duty setting.

12. At this point drive the vehicle again to check the boost level. While in third gear or above if the boost level stabilizes at a point near the specified boost setting the unit will commence the self learning process to complete the setting.

13. If the boost level does not rise enough or overshoots (by over 0.2 k) during step 12 or if the self learning does not start, please reset the duty settings to prevent miscalculations.(return to step 9)

!CAUTION If the boost level does not rise to the specified level even after the duty has been set to 90%, a problem with the turbo may exist. In these cases, please lower the preset boost level.

IMPORTANT * Normally, the set duty level is meant to aid the self learning function according to the corresponding boost level but in vehicles which lose boost at higher RPM's, the duty level may be set to a higher level (A setting which would normally produce a boost overshooting characteristic) to compensate for the boost drop. As the self learning function progresses, the overshoot will gradually be suppressed. (Please set vehicles which lose boost due to lack of injector capacity by the normal method.)

3-2 Wastegate Type

IMPORTANT * Wastegate type vehicles do not differ in the duty setting from actuator type vehicles but the amount of boost control which is possible depends upon the type of spring rate used by the wastegate. As far as the duty setting is concerned, please choose a spring rate which allows the maximum boost pressure to be controlled by a 70% duty setting.

1. Set the desired boost pressure from preset A or B
2. Set the maximum set boost level at a 70% duty level.
3. Drive the vehicle and check the boost level. Adjust the wastegate spring or replace the wastegate spring so that the boost level reaches near the specified setting. While in third gear or above if the boost level stabilizes at a point near the specified boost setting the unit will commence the self learning process to complete the setting.
4. As for the other preset, please set the preset to the same if not a higher boost pressure setting than the one above. Please change the duty level for the new boost pressure as well.

!CAUTION (Same for actuator and wastegate type)

Although this unit has a RPM separate self learning function, vehicles maximizing their injectors by 6200 rpm will not be able to use the self learning function during that period because the unit uses the injector signal to read the engine RPM for the self learning function. In order to have more precise boost control, the solution to this problem is to upgrade to higher capacity injectors.*

*Our company can provide the proper upgrade injectors.

BCNR33/BNR32/RNN14.....550cc/min: Y20000/pc (Part number:404-N001)

ECR33/S14/#PS13.....440cc/min:Y24000/pc (Part number:404-N002)

IMPORTANT (Same for actuator and wastegate type)

* Changes in either the preset boost pressure or duty level will reset the self learning function. (Even if the boost pressure was changed and then returned to its previous setting)

* As long as the basic requirements are fulfilled, the self learning function will automatically proceed under normal driving conditions. Please follow the steps below to speed up the self learning function process.

1. Drive the vehicle in as high of a gear as possible in order to get the boost pressure to match the specified boost level at the lowest possible RPM. (the intercept RPM) (Running the vehicle from the intercept RPM + 1000 RPM is acceptable.)

2. Next, run the vehicle in the mid and high RPM of a mid-range gear to match the specified boost level.

3. Repeating steps 1 and 2 will speed up the self learning function.

4. If the boost pressure does not rise properly, please reset the self learning function or check the set boost pressure again.

* Be sure to reset the duty level and repeat the programming sequence from the beginning when modifying either the actuator or wastegate.

4. Set Up Lock Function

This function allows the user to lock the functions accessible on the front part of the unit. (The steps 1~3 when setting the presets in the set up mode)This safety feature has been designed to prevent the self learning function from being reset by accident, prevent others from modifying the boost pressures and damaging the engine, and to prevent all other potential trouble.

1. While the unit is ON, press both the SELECT and the Up switch immediately.

2. The display will change from the normal screen to unL-000. This unL-000 denotes the lock function has been released.

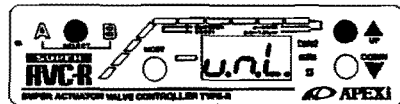

displays the unlocked situation

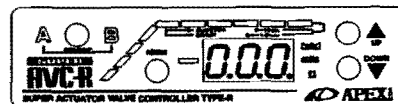

displays the unlock code

3. Set the unlock code by pressing either UP or DOWN. (000~999)

(We recommend writing down the unlock code on a separate sheet of paper for reference.)

4. Set the desired lock code by pressing the MODE switch. The display will read Loc at this time and return to the monitor mode.

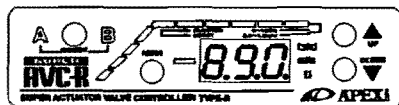

EX: if the lock code is 890

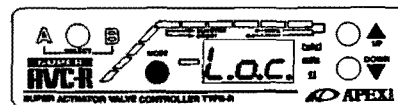

Begin the setup lock

5. Follow the same procedures to unlock the unit.

6. When following step 1 now, the screen will read Loc-000 showing that the unit is locked.

7. Enter the set lock code by using the UP/DOWN button and press the MODE button. If the correct code has been entered, the display will read unL and release the lock.

IMPORTANT* Please start at step 6 if the wrong code has been entered. If the lock code has been lost or forgotten, disconnecting the connector or the battery will release the locking function. This procedure however, will erase all recorded data so please start the programming process from the beginning.

[2] Monitor Mode

1. Boost Pressure Display Function

This unit displays the absolute pressure of 760 mmHg as 0 kg/cm2 and engine boost as kg/cm2. Also the unit reads the absolute pressure of 760 mmHg as 0mmHg and the engine vacuum as minus mmHg.

2.Injector Pulse Display Function

The injector pulse display function of this unit reads the maximum injector capacity as 100% and displays the % of injection from that point. The display will begin to flash if the injectors reach over 98% capacity.

!CAUTION Some vehicles may experience a scattered injector reading under full load because this unit uses the injector signal for its injector pulse display. Vehicles equipped with an electrical current controller for its injectors cannot use this function. (PZ31, R31 etc...)

1. While the ignition key is ON, whether the unit is turned OFF or ON, the display feature will function for both the digital display and bar graph.

2. Since the boost pressure display and injector pulse display is accompanied by the digital and bar graphs, toggling between the two displays is possible. The display limits for boost pressure is -760 mmHg~2.00 kg/cm2, and 0 ~ 100% for injector pulse. The bar graph reads 0.60~1.50 kg/cm2 and 10~100% respectively within the 10 LED's displaying increments of 5 units.

3. Use the MODE switch to toggle between the various displays. For instance, if the present display shows boost display in digital form, the bar graph will denote the injector pulse. Pressing the MODE button again will switch again to the other display.

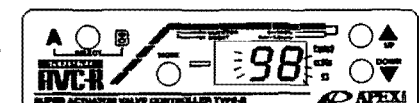
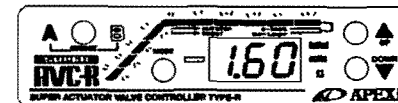

EX: The present display shows boost at 1.60 kg/cm2 and the injector pulse at 98%in bar and digital form.

9. Vehicle Specific Installation Table

1. TOYOTA

Vehicle Name	Model Type	Engine	Year	ECU Location	ECU Wiring	
Aristo	J Z S 1 4 7	2 J Z - G T E	'91.10~	c	T 1	
Soarer	J Z Z 3 0	1 J Z - G T E	'91.5~	c	T 2	
	M Z 2 0	7 M - G T E	'88.1~'91.5	d	T 4	
			'86.1~'88.1		T 7	
G Z 2 0	1 G - G T E	'89.1~'91.5	d	T 4		
		'86.1~'89.1		T 7		
Supra	J Z A 8 0	2 J Z - G T E	'93.5~	c	T 1	
	J Z A 7 0	1 J Z - G T E	'90.8~'93.5	d	T 3	
	M A 7 0	7 M - G T E	'88.8~'90.8		T 4	
			'86.1~'88.8		T 7	
G A 7 0	1 G - G T E	'88.8~'93.4	T 4			
		'86.1~'88.8	T 7			
MarkII	J Z X 9 0	1 J Z - G T E	'92.12~	e	T 2	
Chaser	J Z X 8 1		'90.8~'92.9	d	T 3	
Cresta	G X 8 1	1 G - G T E	'88.8~'92.9		T 4	
MR2	S W 2 0	3 S - G T E	'89.10~	Trunk	T 4	
Celica	S T 2 0 5	3 S - G T E	'94.2~	e	T 4	
	S T 1 8 5		'89.10~'93.9			
	S T 1 6 5		'85.8~'89.9		T 8	
Starlet	E P 9 1	4 E - F T E	'95.12~	d	T 5	
	E P 8 2 (M/T)		(A/T)	'89.12~'95.12	e	T 6
				'92.1~'95.12		T 5
	E P 7 1	2 E - T E	'86.1~'89.12		T 9	

2. NISSAN

Vehicle Name	Model Type	Engine	Year	ECU Location	ECU Wiring
Cima	F H Y 3 3	V Q 3 0 D E T	'96.6~	a	N 3
	F P Y 3 2		'93.9~'93.6		N 1
	F P Y 3 1	V G 3 0 D E T	'89.8~'91.7		d
'88.1~'89.7					
Fairlady Z	Z 3 2	V G 3 0 D E T T	'89.7~	c	N 1
Leopard	J H Y 3 3	V Q 3 0 D E T	'96.3~	a	N 3
	U F 3 1	V G 3 0 D E T	'88.8~'92.6		N 1
	G F 3 1	V G 2 0 D E T			N 4
Cedric	Y 3 3	V Q 3 0 D E T	'95.6~	a	N 3
Gloria	Y 3 2	V G 3 0 D E T	'91.6~'95.6		N 1
	Y 3 1	V G 2 0 D E T	'89.6~'91.6		
Cefiro	A 3 1	R B 2 0 D E T	'88.9~'94.8		N 1
Laurel	C 3 4	R B 2 5 D E T	'94.1~	a	N 1
	C 3 3	R B 2 0 D E T	'88.12~'93.1		
Skyline	R 3 3	R B 2 6 D E T T	'95.1~	a	N 1
		R B 2 5 D E T	'93.8~		
	R 3 2	R B 2 6 D E T T	'89.8~'95.1		
		R B 2 0 D E T	'89.5~'93.8		
Bluebird	U 1 3	S R 2 0 D E T	'91.9~'96.1	e	N 2
	U 1 2		'89.10~'91.9		
			C A 1 8 D E T		
Silvia	S 1 4	S R 2 0 D E T	'96.6~	a	N 2
			'93.10~'96.6		N 1
	PS 1 3		'91.1~'93.10		N 2
	S 1 3	C A 1 8 D E T	'88.5~'91.1		N 1
180SX	R P S 1 3	S R 2 0 D E T	'91.1~	a	N 2
	R S 1 3	C A 1 8 D E T	'89.3~'91.1		N 1
Pulsar	N 1 4	S R 2 0 D E T	'90.8~'95.1	e	N 2
Avenir	W 1 0	S R 2 0 D E T	'95.8~	e	N 2

3. MITSUBISHI

Vehicle Name	Model Type	Engine	Year	ECU Location	ECU Wiring
GTO	Z 1 6 A	6 G 7 2	'90.10~	The back of radio	M 1
Galant	E 8 4 A	6 A 1 2	'92.5~	e	M 1
	E 3 9 A	4 G 6 3	'87.10~'92.4	b	M 2
Eclipse	D 3 2 A	4 G 6 3	'95.6~'	The back of radio	M 4
	D 2 7 A		'89.11~'95.6		M 2
Lancer	C M 5 A	4 G 9 3	'95.10~	b	M 1
	C E 9 A	4 G 6 3	'93.10~'95.10		
	C D 9 A		'92.10~'93.10		
	C D 5 A	4 G 9 3	'91.10~'95.10		
Libero	C D 5 W	4 G 9 3	'94.1~	b	M 1
RVR	N 2 3 W	4 G 6 3	'94.9~	b	M 1

4. MAZDA

Vehicle Name	Model Type	Engine	Year	ECU Location	ECU Wiring
Cosmo	J C E S	2 0 B - R E W	'90.3~'95.12	c	Z 1
	J C 3 S	1 3 B - R E W			
RX-7	F D 3 S	1 3 B - R E W	'95.12~	a	Z 5
			'91.12~'95.12		Z 1
	F C 3 S	1 3 B	'88.9~'91.12	c	Z 2
			'85.10~'88.9		Z 3
Familia	B G - 8 Z	B P - Z E T	'92.1~'94.6	e	Z 4

5. SUBARU

Vehicle Name	Model Type	Engine	Year	ECU Location	ECU Wiring
Legacy	BD 5	E J 2 0 R	'96.6~	c	F 3
	BG 5	E J 2 0 H (MT)			F 4
		E J 2 0 H (AT)			F 1
	E J 2 0 H	'93.10~'96.6			
	BC 5	E J 2 0 G	'89.2~'93.10	h	F 2
	BF 5				
Imprezza	GC 8	E J 2 0 G	'92.11~	c	F 2
	GF 8		'93.10~		

10. Vehicle Specific Computer Location Diagram

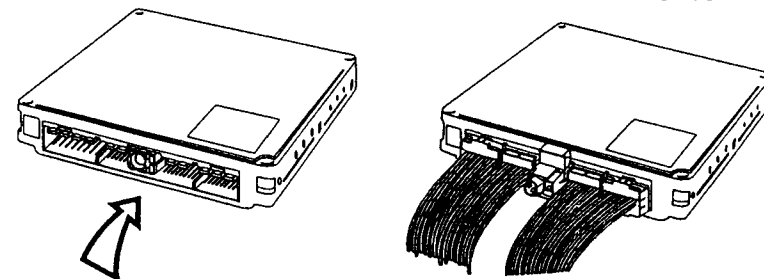
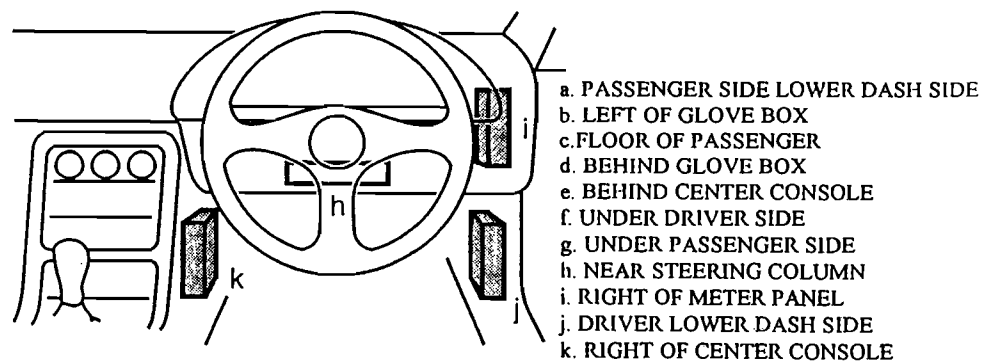
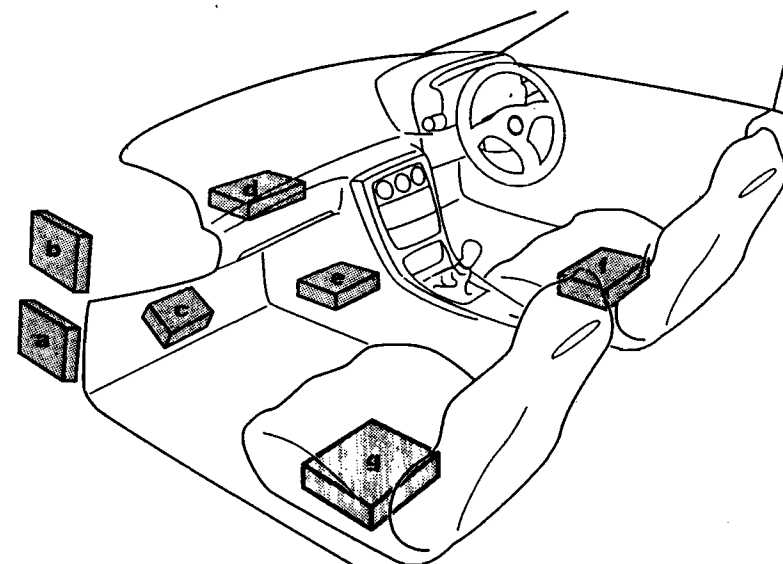

The Vehicle Specific Computer Wiring Diagram views the coupler from this angle. Some vehicles may have the computer mounted backwards. Please check the coupler pin numbers to be sure.

II. Vehicle Specific Computer Wiring Diagram

1. TOYOTA

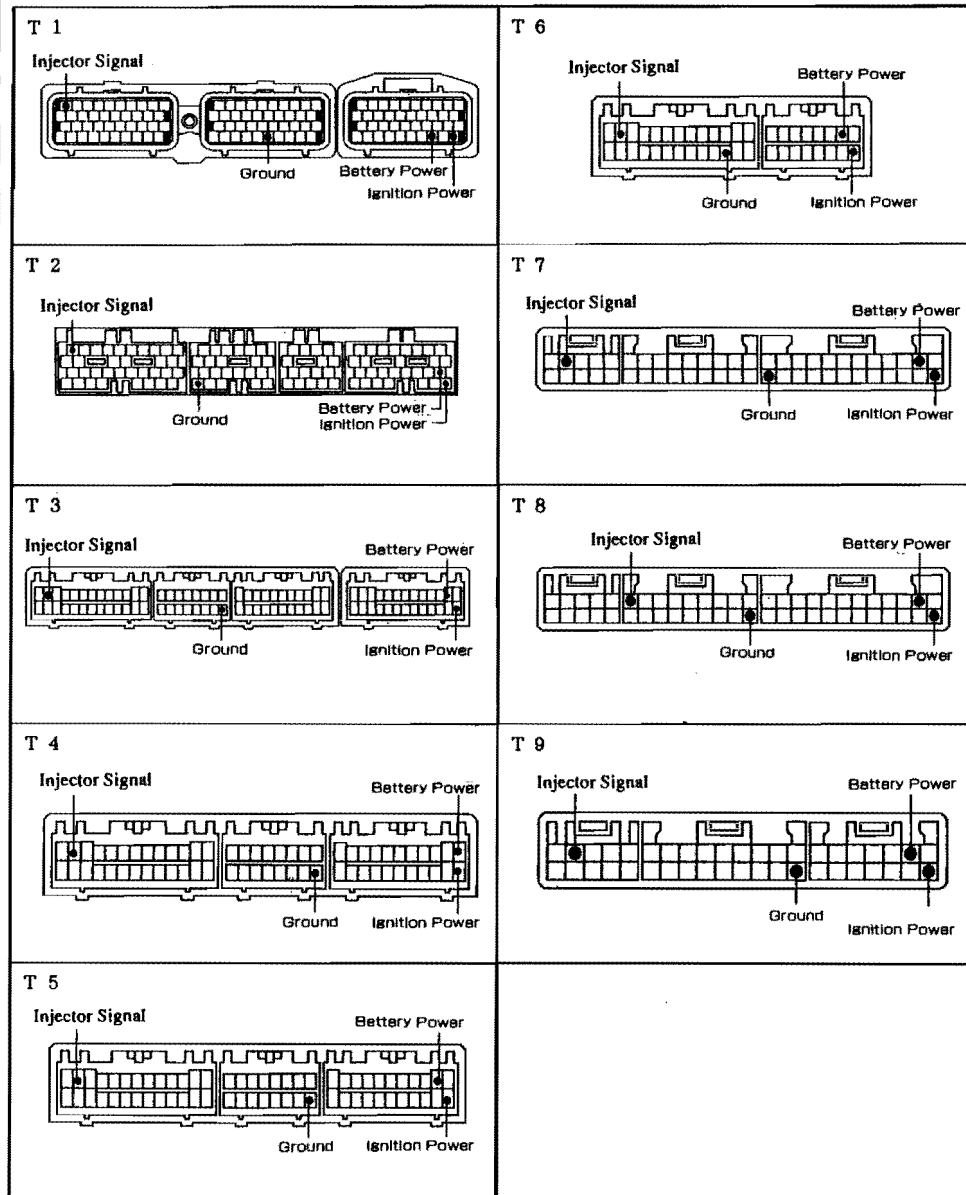

2. NISSAN

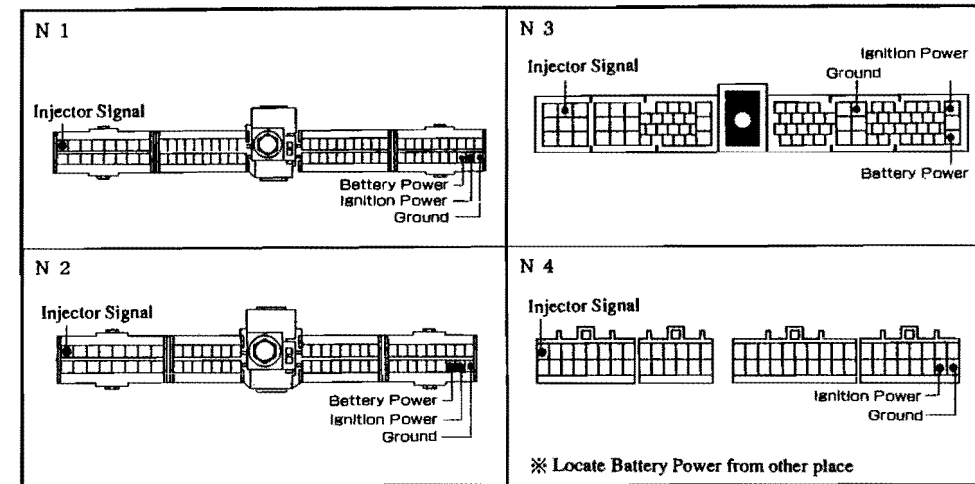

3. MITSUBISHI

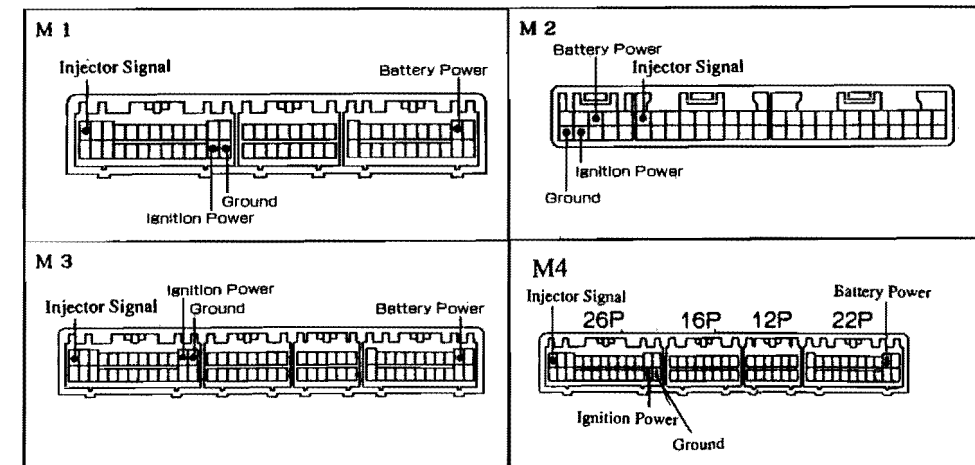

4. MAZDA

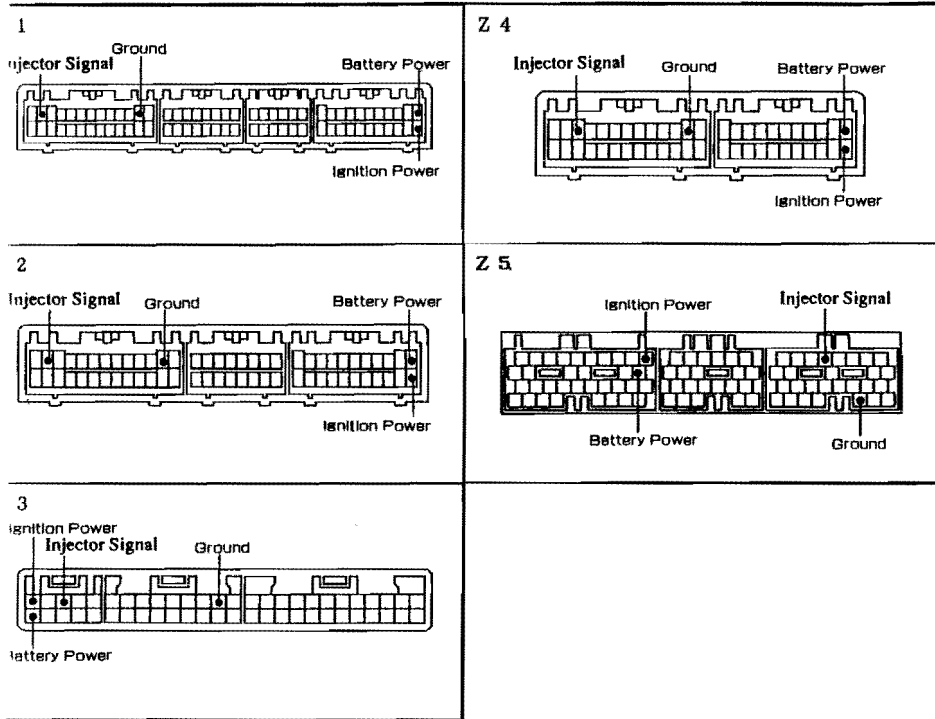

5. SUBARU

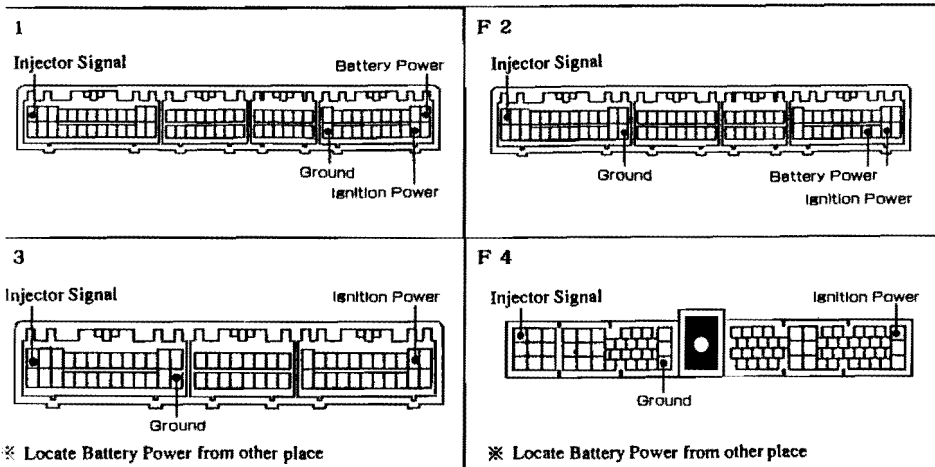

* Actuator Type Vehicle Specific Piping Diagram

CAUTION For vehicles require special piping, failure to pipe the hoses may cause the unit to function improperly.

1. Vehicles With Boost Pressure Regulating Solenoid Valve (NISSAN * MITSUBISHI type)

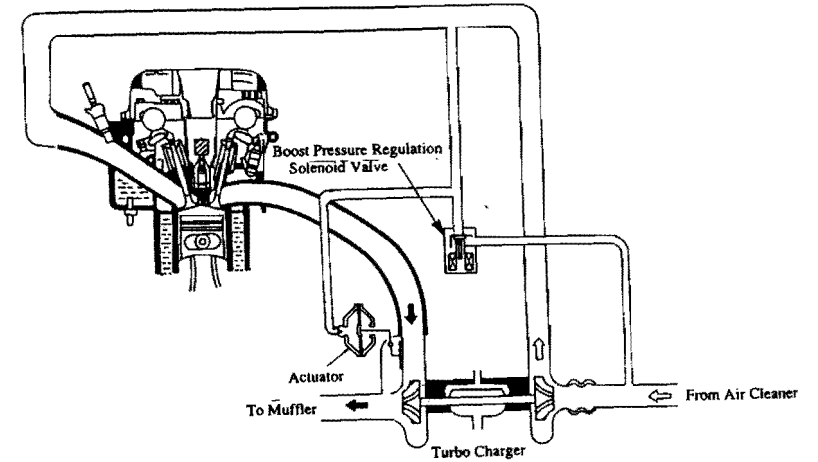

Normal vehicle piping diagram

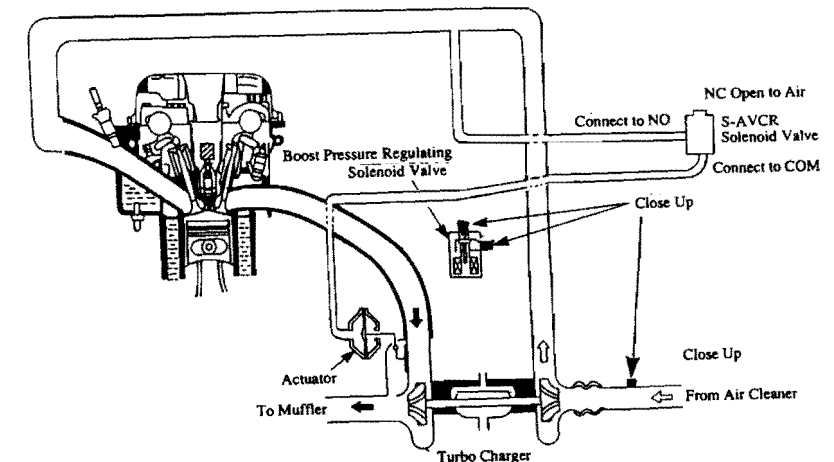

Super AVC-R piping diagram

2. Vehicles with Boost Pressure Regulating Solenoid Valve
(TOYOTA, MAZDA type)

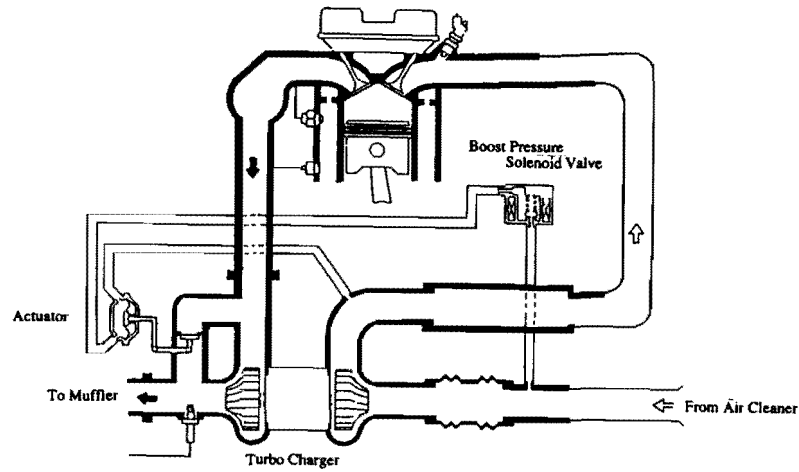

Normal vehicle piping diagram

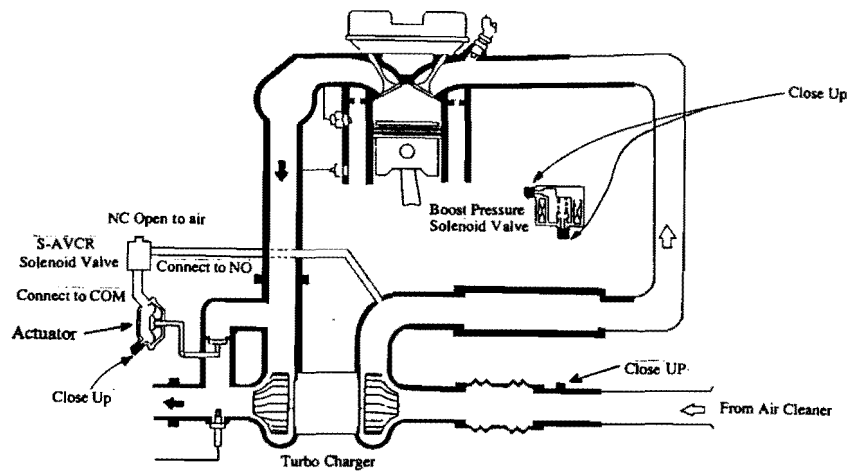

Super AVC-R piping diagram

3. JZA80 Supra, JZS147 Aristo (2JZ-GTE) Specific Piping Diagram

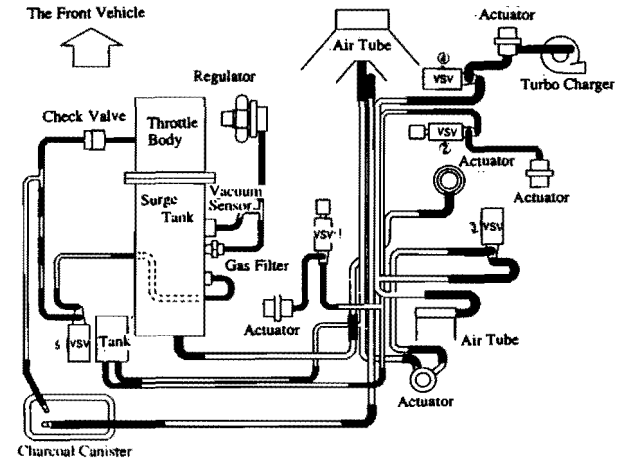

Normal vehicle piping diagram

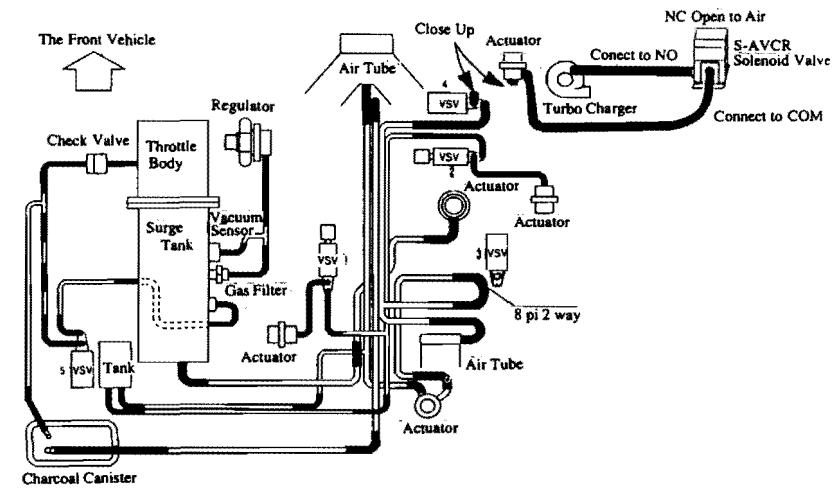

Super AVC-R specific piping diagram

4. FD3S Enfini RX-7 (13B-REW) Specific Piping Diagram

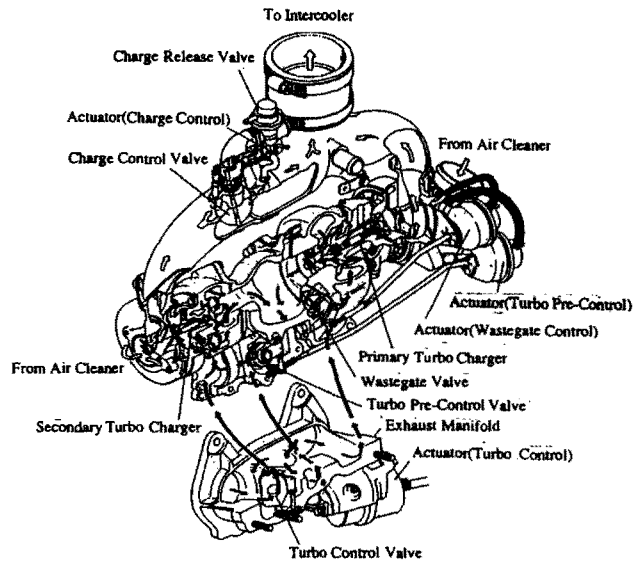

Normal vehicle piping Diagram

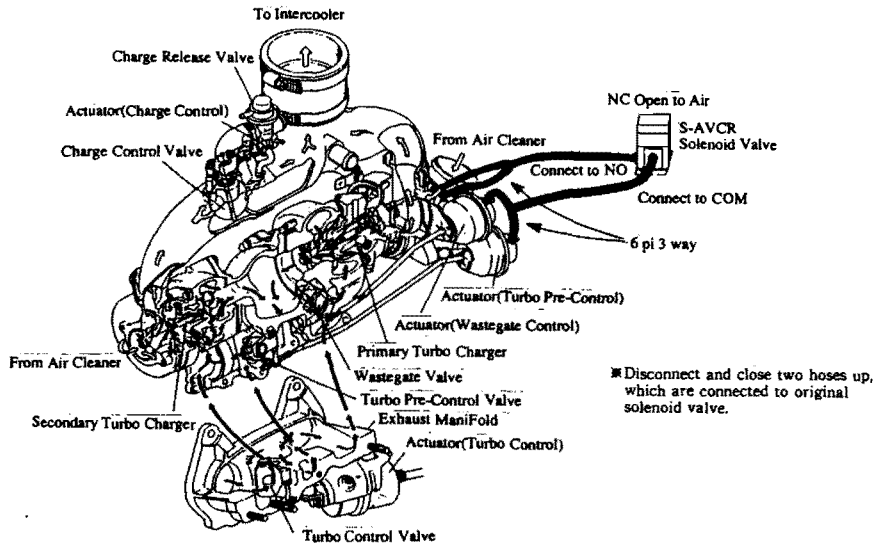

Super AVC-R specific piping diagram

5. BD5,BG5 Legacy (EJ20H) specific piping diagram

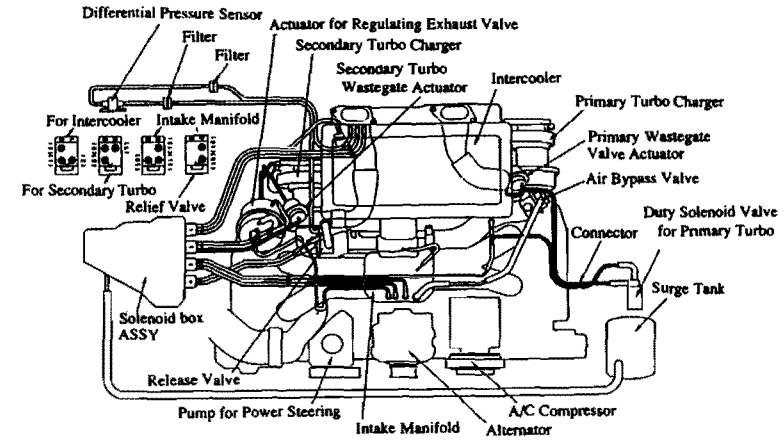

Normal vehicle piping diagram

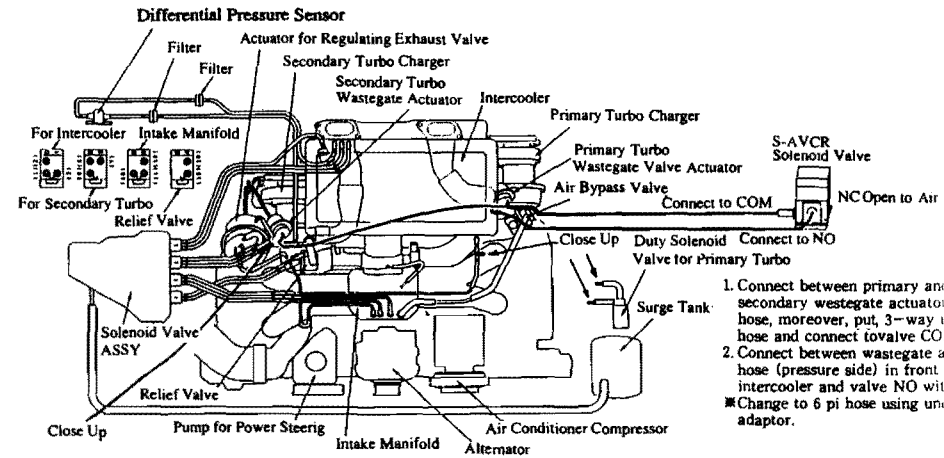

Super AVC-R Piping Diagram